

ASSEMBLY INSTRUCTIONS MODEL 9209G  
 REMOVE ALL ITEMS FROM THE CARTON. VERIFY ALL PIECES BEFORE ASSEMBLY

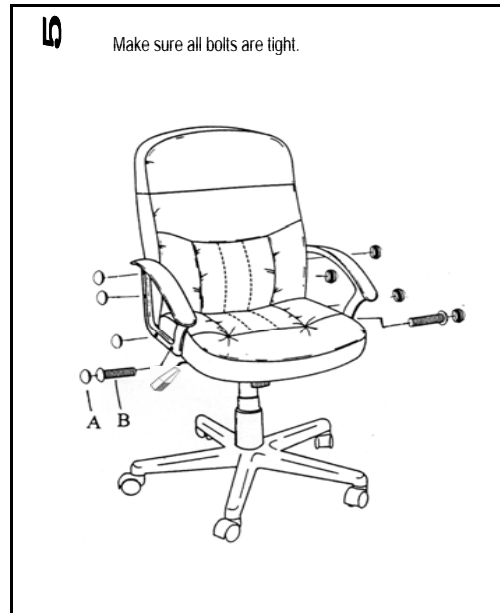
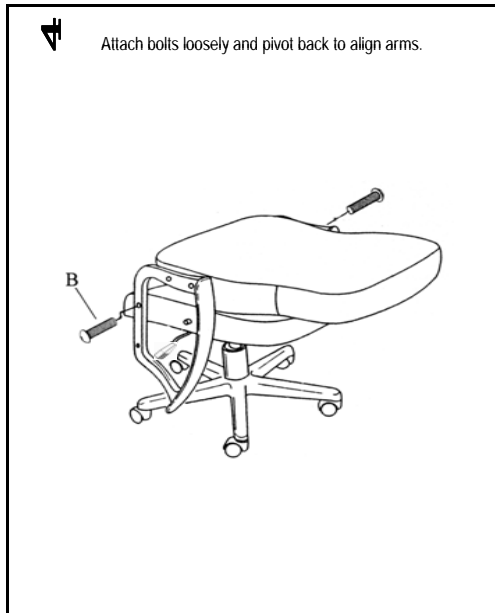
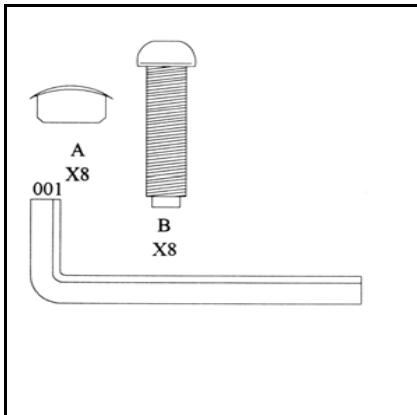
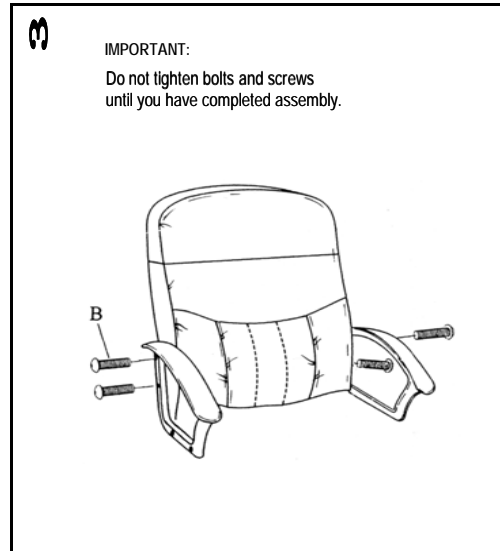
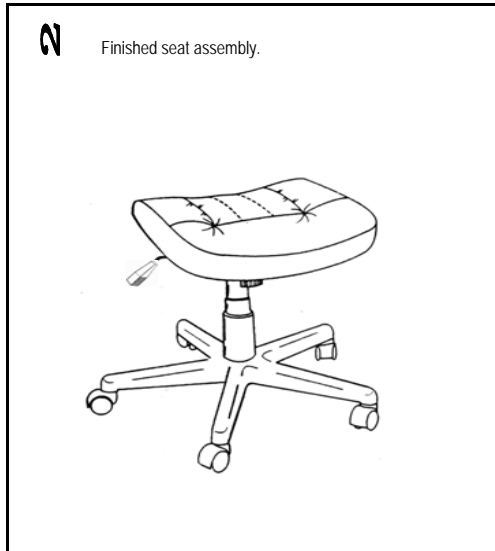
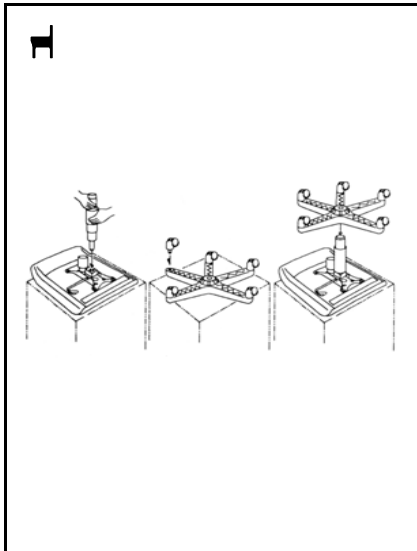

		QTY
A	PLASTIC CAP	8
B	SCREW	8
001	ALLEN WRENCH FOR SCREWS (B)	1

**6 OPERATING INSTRUCTIONS**

**A. SEAT HEIGHT ADJUSTMENT**

- TO RAISE THE SEAT:
  - LEAN SLIGHTLY FORWARD WHILE SEATED-TO RELIEVE THE PRESSURE ON THE TILT MECHANISM.
  - REACH UNDER THE RIGHT SIDE OF THE CHAIR AND LOCATE THE HANDLE AND RAISE YOURSELF UP SLIGHTLY TO ALLOW THE CHAIR TO REACH YOUR DESIRED HEIGHT.
- TO LOWER THE SEAT:
  - REMAIN SEATED AND LIFT THE HANDLE UPWARDS UNTIL THE CHAIR LOWERS TO YOUR DESIRED HEIGHT.

**B. TO OPERATE TILT LOCKOUT:**

TILT "LOCKOUT" LOCKS THE CHAIR IN THE UPRIGHT POSITION ONLY. PULLING HANDLE ALL THE WAY OUT, ALLOWS THE CHAIR TO TILT. PUSHING THE HANDLE "IN", LOCKS IN THE FULLY UPRIGHT POSITION.

**C. TILT TENSION ADJUSTMENT:**

GRASP THE ROUND CYLINDER KNOB UNDER THE FRONT CENTER SEAT.

- FOR FIRMER/STIFFER-TURN CLOCKWISE.
- FOR SOFTER/LOOSER-TURN COUNTER CLOCKWISE.

POSITION

LOCK ← FREE →

UP OR DOWN ↑

PREVENTATIVE MAINTENANCE AND WARNING  
 USE THIS PRODUCT ONLY FOR SEATING ONE PERSON AT A TIME  
 DO NOT USE CHAIR AS STEP STOOL/LADDER  
 DO NOT USE CHAIR UNLESS ALL BOLTS, SCREWS ARE TIGHT  
 CHECK AND RETIGHTEN ALL BOLTS, SCREWS EVERY 6 MONTHS

ANY QUESTIONS PLEASE CONTACT  
 CHAIRWORKS AMERICA  
 755 RACK DRIVE, SUITE A  
 LAWRENCEVILLE, GA 30046  
 1-888-217-2577