

ASSEMBLY INSTRUCTIONS MODEL 9363U & 9364U

REMOVE ALL ITEMS FROM THE CARTON. VERIFY ALL PIECES BEFORE ASSEMBLY

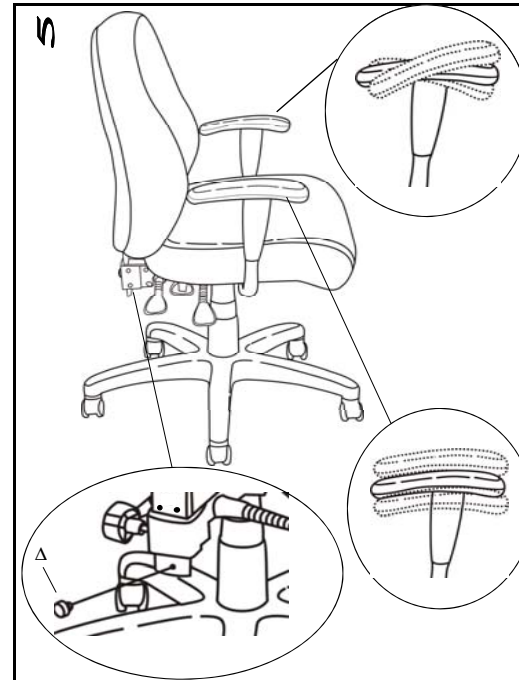
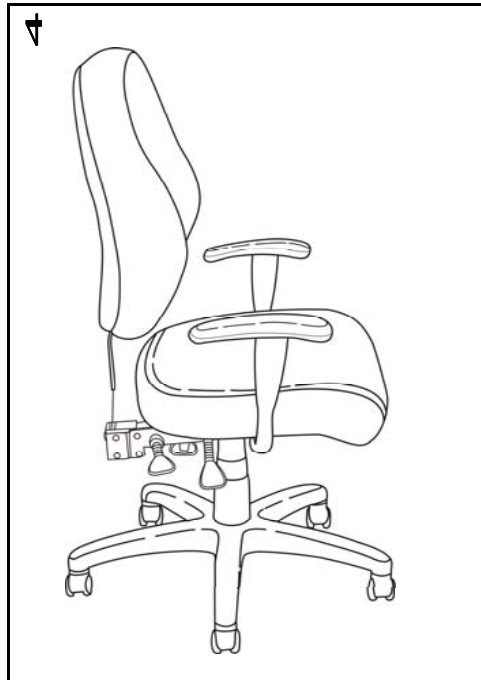
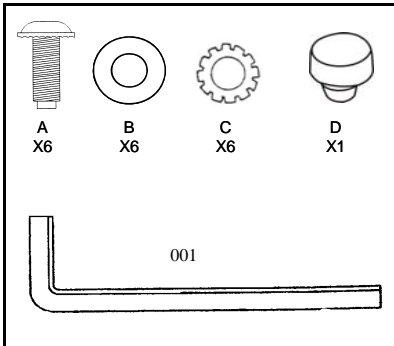
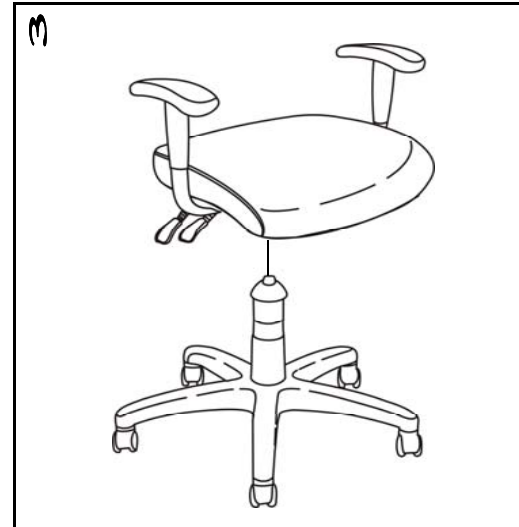
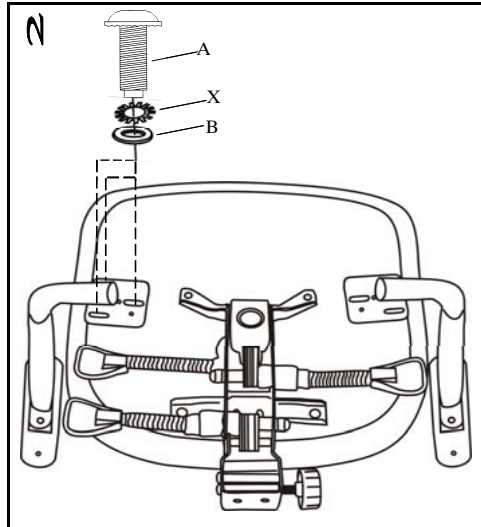
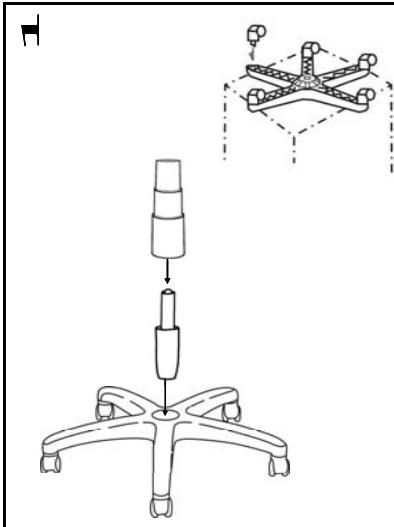

OPERATING INSTRUCTIONS

A. SEAT HEIGHT ADJUSTMENT

- TO RAISE THE SEAT:
 - LEAN SLIGHTLY FORWARD WHILE SEATED-TO RELIEVE THE PRESSURE ON THE TILT MECHANISM.
 - REACH UNDER THE RIGHT SIDE OF THE CHAIR AND LOCATE THE HANDLE AND RAISE YOURSELF UP SLIGHTLY TO ALLOW THE CHAIR TO REACH YOUR DESIRED HEIGHT.
- TO LOWER THE SEAT:
 - REMAIN SEATED AND LIFT THE HANDLE UPWARDS UNTIL THE CHAIR LOWERS TO YOUR DESIRED HEIGHT.

B. SEAT POSTURE ADJUSTMENT

- PULL THE HANDLE 'UP' TO FREE THE MOVEMENT TO YOUR DESIRED ANGLE.
- PUT THE HANDLE 'DOWN' TO LOCK AND FIX YOUR DESIRED POSITION.

C. BACK POSTURE ADJUSTMENT

- PULL THE HANDLE 'UP' TO FREE THE MOVEMENT TO YOUR DESIRED ANGLE.
- PUT THE HANDLE 'DOWN' TO LOCK AND FIX YOUR DESIRED POSITION.

D. BACK HEIGHT ADJUSTMENT

- LOOSEN (COUNTER CLOCKWISE/LEFT) THE KNOB (BE SURE THE UPRIGHT STEEL SUPPORT IS ALIGNED PROPERLY IN THE HOLDER)
- MVGE THE BACK UP OR DOWN TO YOUR DESIRED POSITION
- TIGHTEN THE KNOB (CLOCKWISE/RIGHT) TO FIX THE HEIGHT LOCATION.

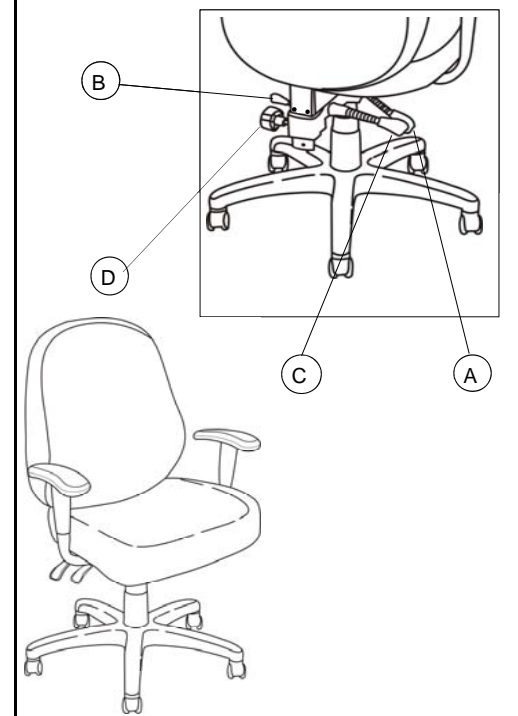

		QTY
A	SCREW	6
B	FLAT WASHER	6
C	LOCK WASHER	6
D	PLASTIC CAP	1
001	ALLEN WRENCH FOR SCREWS(A)	1

PREVENTATIVE MAINTENANCE AND WARNING

USE THIS PRODUCT ONLY FOR SEATING ONE PERSON AT A TIME
 DO NOT USE CHAIR AS STEP STOOL/LADDER
 DO NOT USE CHAIR UNLESS ALL BOLTS, SCREWS ARE TIGHT
 CHECK AND RETIGHTEN ALL BOLTS, SCREWS EVERY 6 MONTHS

ANY QUESTIONS PLEASE CONTACT
 CHAIRWORKS AMERICA
 755 RACK DRIVE, SUITE A
 LAWRENCEVILLE, GA 30046
 1-888-217-2577