

ASSEMBLY INSTRUCTIONS MODEL 9532N

REMOVE ALL ITEMS FROM THE CARTON. VERIFY ALL PIECES BEFORE ASSEMBLY

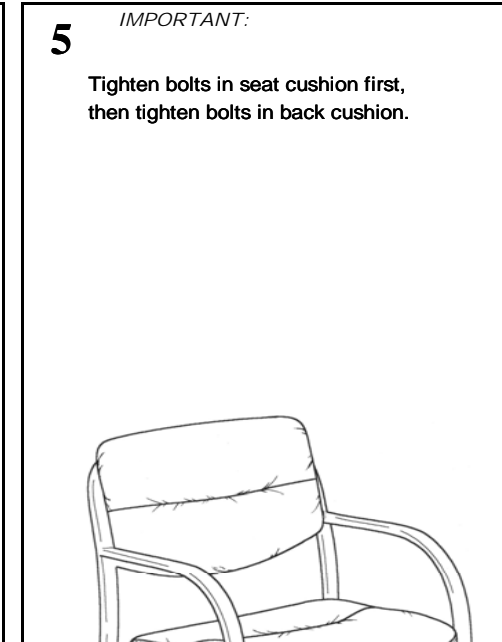

		QTY
A	SCREW	4
B	SCREW	4
001	ALLEN WRENCH FOR SCREWS (A,B)	1

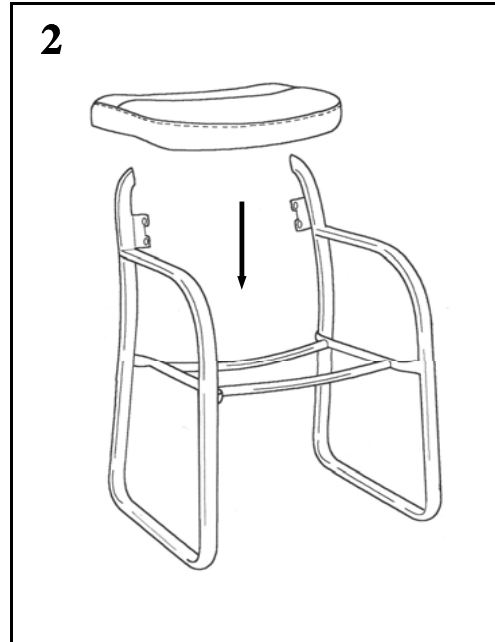
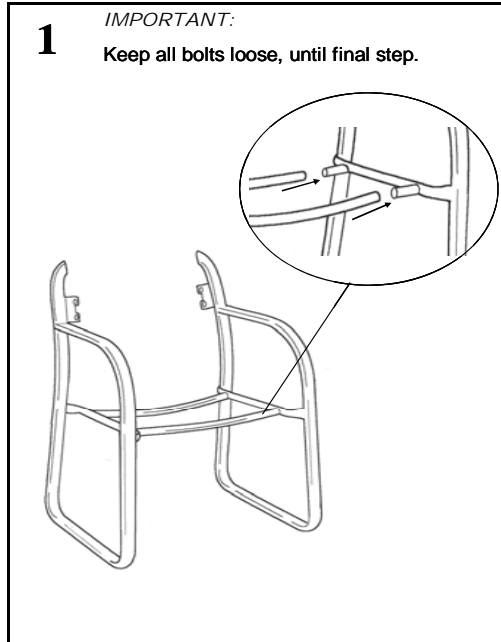
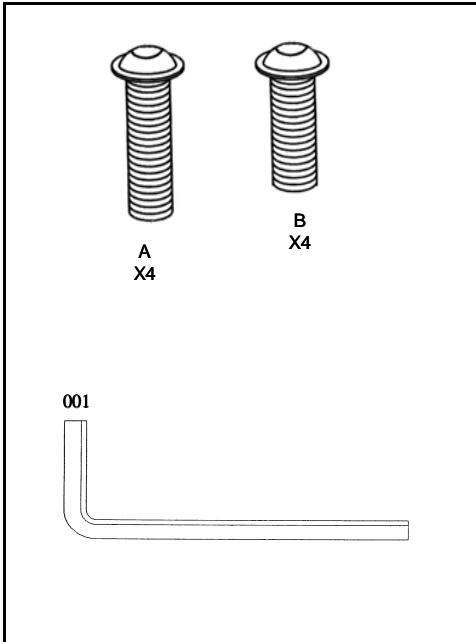
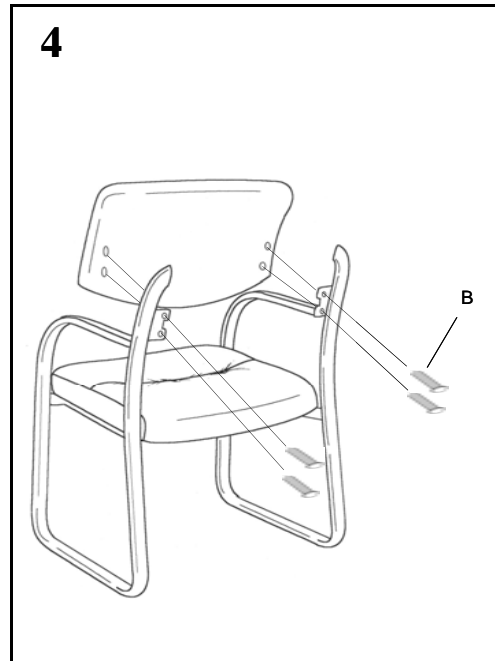
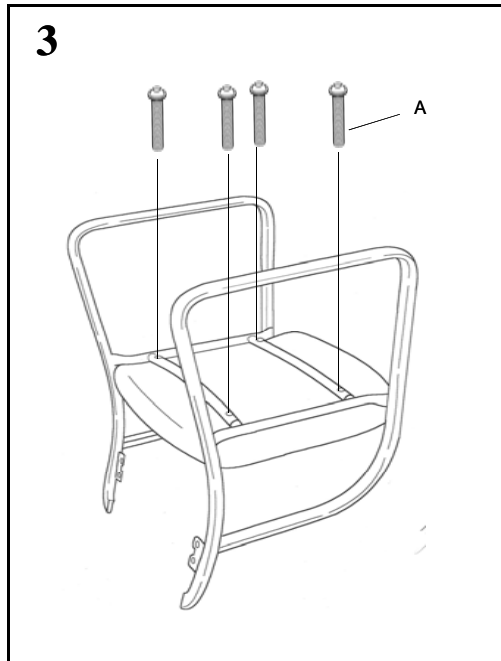

Please make sure all bolts are tight before using.

PREVENTATIVE MAINTENANCE AND WARNING
 USE THIS PRODUCT ONLY FOR SEATING ONE PERSON AT A TIME
 DO NOT USE CHAIR AS STEP STOOL/LADDER
 DO NOT USE CHAIR UNLESS ALL BOLTS, SCREWS ARE TIGHT
 CHECK AND RETIGHTEN ALL BOLTS, SCREWS EVERY 6 MONTHS

ANY QUESTIONS PLEASE CONTACT
 CHAIRWORKS AMERICA
 755 RACK DRIVE, SUITE A
 LAWRENCEVILLE, GA 30046
 1-888-217-2577