

# ASSEMBLY INSTRUCTIONS MODEL 9826Z

REMOVE ALL ITEMS FROM THE CARTON. VERIFY ALL PIECES BEFORE ASSEMBLY



## 9826Z



Part	QTY
A: SCREW	4
B: LOCK WASHER	4
C: FLANGE WASHER	4
D: SCREW	2
E: PLASTIC KNOB	2
001: ALLEN KEY FOR SCREWS (A)	1
002: ALLEN KEY FOR SCREWS (D)	1

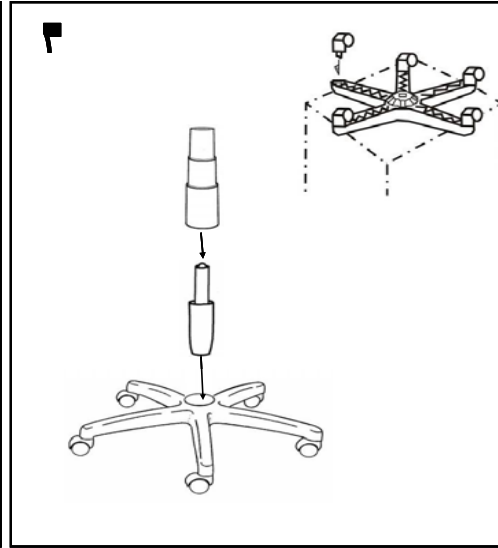

### OPERATING INSTRUCTIONS

#### A. SEAT HEIGHT ADJUSTMENT

- TO RAISE THE SEAT:
  - LEAN SLIGHTLY FORWARD WHILE SEATED TO RELIEVE THE PRESSURE ON THE TILT MECHANISM.
  - REACH UNDER THE RIGHT SIDE OF THE CHAIR AND LOCATE THE HANDLE AND RAISE YOURSELF UP SLIGHTLY TO ALLOW THE CHAIR TO REACH YOUR DESIRED HEIGHT.

#### ■ TO LOWER THE SEAT:

- REMAIN SEATED AND LIFT THE HANDLE UPWARDS UNTIL THE CHAIR LOWERS TO YOUR DESIRED HEIGHT.

#### B. TO OPERATE TILT LOCKOUT:

TILT "LOCKOUT" LOCKS THE CHAIR IN EITHER THE UPRIGHT OR FULLY TILT POSITIONS ONLY. PULLING THE HANDLE UNDER THE LEFT SIDE OF THE CHAIR ALL THE WAY OUT ALLOWS THE CHAIR TO TILT PUSHING THE HANDLE IN EITHER THE FULLY TILT OR FULLY UPRIGHT POSITION LOCKS THE TILT MOVEMENT.

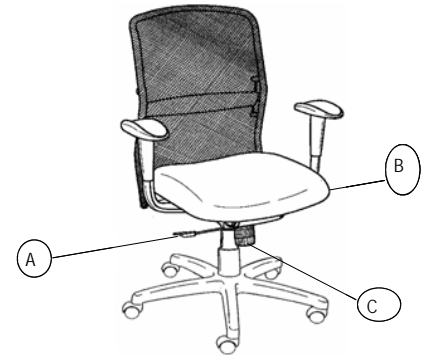

#### C. TILT TENSION ADJUSTMENT:

GRASP THE ROUND CYLINDER KNOB UNDER THE FRONT CENTER SEAT.

- FOR FIRMER/STIFFER-TURN CLOCKWISE.
- FOR SOFTER/LOOSER-TURN COUNTER CLOCKWISE.

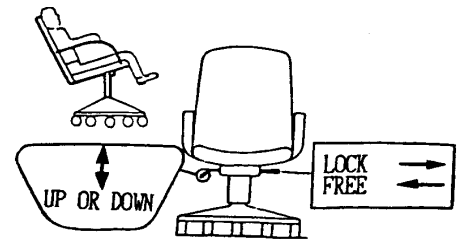

#### PREVENTATIVE MAINTENANCE AND WARNING

- USE THIS PRODUCT ONLY FOR SEATING ONE PERSON AT A TIME
- DO NOT USE CHAIR AS STEP STOOL/LADDER
- DO NOT USE CHAIR UNLESS ALL BOLTS, SCREWS ARE TIGHT
- CHECK AND RETIGHTEN ALL BOLTS, SCREWS EVERY 6 MONTHS

#### ANY QUESTIONS PLEASE CONTACT

CHAIRWORKS AMERICA  
755 RACK DRIVE, SUITE A  
LAWRENCEVILLE, GA 30046  
1-888-217-2577